

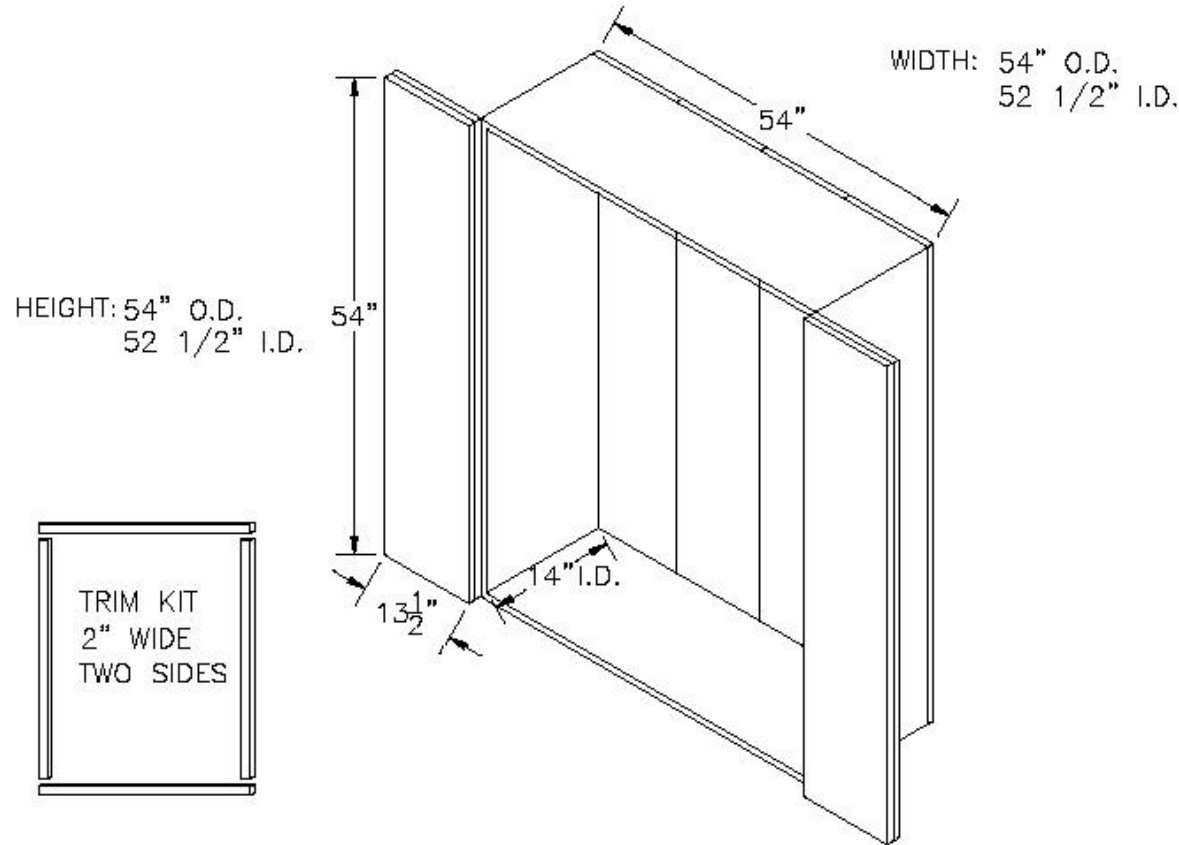

PX96 X-RAY PASS THRU



NOTE: HOLE IN WALL SHOULD BE APPROX. 1/2" LARGER ON ALL SIDES



DEALER: _____

LOC: _____

DOCTOR: _____

P.O.# _____

W/O# _____

START DATE: _____

ORDER DATE: _____

APPROX. SHIP: _____

SET UPS: _____

TOP COLOUR: -

CAB COLOUR: -

ACCENT COLOUR: -

HANDLES: _____

PVC EDGE: _____

HARDWARE: REG CLOSE DOORS
REGULAR EXTENSION
REGULAR CLOSE DRAWERS

SKETCH #: -

REVISIONS		REVISIONS	
-	-	-	-
-	-	-	-
-	-	-	-

NOTE: PLUMBING & ELECTRICAL SPECS WILL BE PROVIDED AT THE TIME OF ORDER